

Installation dimensions

If required, the installation position may be adjusted using the two mounting clamps.

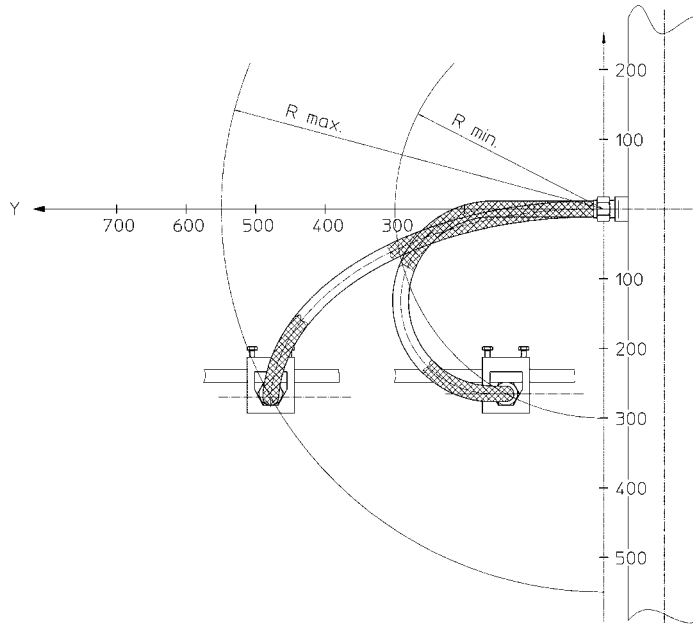

Please select distance dimensions x from the respective table (right).

Sprinkler mounting systems are suited for use with tap water / drinking water at ambient temperatures. When installing, starting and operating the sprinkler system, please ensure that there are no concentrations above 50 ppm (corresponds to 50 mg/l) of corrosion-critical materials in the water (e.g. chloride, fluoride etc.) in the area of the sprinkler hoses. Because of the risk of corrosion, please ensure that contaminants such as dirt, rust particles or metal shavings do not enter the sprinkler hoses during installation. The hoses must be protected from corrosion by foreign materials with appropriate measures, e.g. rinsing of the pipe, filters etc. Technical staff must be consulted in the event of divergent installation and/or operating conditions.

Installation dimensions

HYDRA sprinkler hose and mounting system: Installation dimensions

x = Distance axis hose outlet / suspended ceiling (see installation diagram)

ND 20	x	R min.	R max.
NL 1000	< 200	0	800
	300	0	750
	400	0	700
	500	0	650
	600	0	600
	700	0	500
NL 1200	< 200	0	1000
	400	0	900
	500	0	850
	600	0	800
	700	0	700
	800	0	600
NL 1500	< 300	0	1200
	400	0	1150
	500	0	1150
	600	0	1100
	700	0	1100
	800	0	1100
NL 2000	< 300	0	1750
	400	0	1700
	500	0	1700
	600	0	1650
	700	0	1650
	800	0	1600
	900	0	1550
	1000	0	1500

Installation dimensions

HYDRA sprinkler hose and mounting system: Installation dimensions

x = Distance axis hose outlet / suspended ceiling (see installation diagram)

ND 25	x	R min.	R max.
NL 1000	< 200	not recommended	
	300	not recommended	
	400	300	700
	500	200	650
	600	100	600
	700	0	500
NL 1200	< 200	0	1000
	400	0	900
	500	0	850
	600	0	800
	700	0	700
	800	0	600
NL 1500	< 300	0	1200
	400	0	1150
	500	0	1150
	600	0	1100
	700	0	1100
	800	0	1100
NL 2000	< 300	0	1750
	400	0	1700
	500	0	1700
	600	0	1650
	700	0	1650
	800	0	1600
	900	0	1550
	1000	0	1500

Mounting

The sprinkler hose is to be installed freely between the concrete slab and suspended ceiling and not rest against the concrete slab itself or other technical equipment. Please also ensure that the bending radii for the sprinkler hoses do not fall below the minimum value. A minimum clearance H (min.) between concrete slab and suspended ceiling must be adhered to.

Nominal Diameter	Minimum Bending radius	Minimum clearance H (min.)	
		straight construction	90° bend
ND 20	70 mm	240 mm	170 mm
ND 25	85 mm	265 mm	170 mm

Where installation space is tight, the use of sprinkler hoses with a 90° bend is recommended: In that case, the minimum clearance H (min.) is only 170 mm.

3.6. Mounting of covering rosette

The last mounting step involves the mounting of the covering rosette from the underside of the suspended ceiling.

3.7. Hoses with 90° bends

When installing sprinkler hoses with a 90° bend, please ensure that the hoses are installed as torsion-free as possible. The upright position of the sprinkler socket can be achieved by screwing the hose into the threaded socket of the main supply pipe. Subsequent turning of the hose along its axis is not permissible.



WITZENMANN  
managing flexibility

Sprinkler systems – installation and mounting



Witzenmann GmbH

Östliche Karl-Friedrich-Str. 134  
75175 Pforzheim  
Germany  
Phone +49 - (0)72 31 - 581-0  
Fax +49 - (0)72 31 - 581-820  
e-mail: wi@witzenmann.com  
www.witzenmann.com



**1. GENERAL**

Conventional mounting of sprinklers in suspended ceilings with rigid pipes is very elaborate: the traditional "alignment" as per a pre-defined ceiling plan, which is individually tailored to the respective ceiling system, is very costly with regards to both time and money. The flexibility of a stainless steel hose provides the opportunity to freely choose the installation position of the sprinkler within a circular area defined by the hose length. This allows the problem-free and precise positioning of the sprinklers in suspended ceiling systems of a wide variety of different constructions. It also results in significant time and cost advantages compared to conventional mounting techniques. The mounting brackets which are also provided enable a reliable and secure mounting of the sprinkler hose to the substructure of the respective ceiling system.

**2. AREAS OF APPLICATION / APPROVALS**

Sprinkler mounting systems are certified by the German VdS (Association of Indemnity Insurers, Incorporated Society) and are approved for use in wet pipe systems (PN 16 bar) with sprinklers R3/8" (K57), R1/2" (K 80) and R3/4" (K 115). The approval is only valid in conjunction with the ceiling systems outlined in our technical product descriptions. The sprinkler installation companies must also ensure that the installation of sprinkler mounting systems is only carried out in conjunction with these types of ceiling systems.

The new generation of variable sprinkler mounting systems is based on the use of a 15x15 mm square pipe as a cross beam. The sprinkler hose is firmly attached to the square pipe using a sprinkler clamp, whereby the sprinkler clamp can be moved freely across the entire length of the square pipe. The square pipe is firmly screwed to the substructure of the suspended ceiling using the provided mounting clamps.

**Scope of delivery for variable HYDRA® sprinkler mounting systems:**

- 1 x sprinkler hose
- 1 x square pipe 700 mm, for grid dimensions 600 mm / 625 mm (1400 mm square delivered on request)
- 1 x sprinkler clamp with 2 screws SW10
- 2 x mounting clamps, each with one screw SW10

Two types of mounting clamps can be supplied. Both types are VdS approved.



**Type 1: for hanging standard sprinklers**

For hanging standard sprinklers we recommend the variable sprinkler mounting system for a space-saving installation with a low construction height (see mounting diagram below). The mounting clamps are designed in such a way that the square pipe abuts directly on the substructure of the suspended ceiling.

**Areas of application Type 1:**

- for hanging standard sprinklers
- suitable for all commercially available T-bar lay-in-ceilings (with mineral fibre board or metal cassettes)
- Mounting on main or auxiliary T-bars
- Clamping profile ceiling systems
- Mounting clamps suitable for round and angled contours (profile width > 5mm).

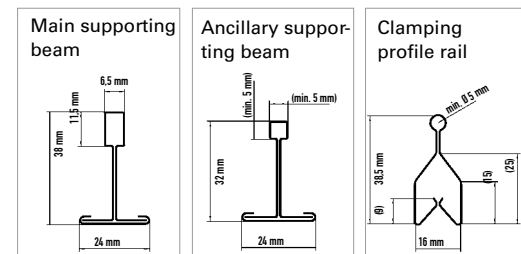
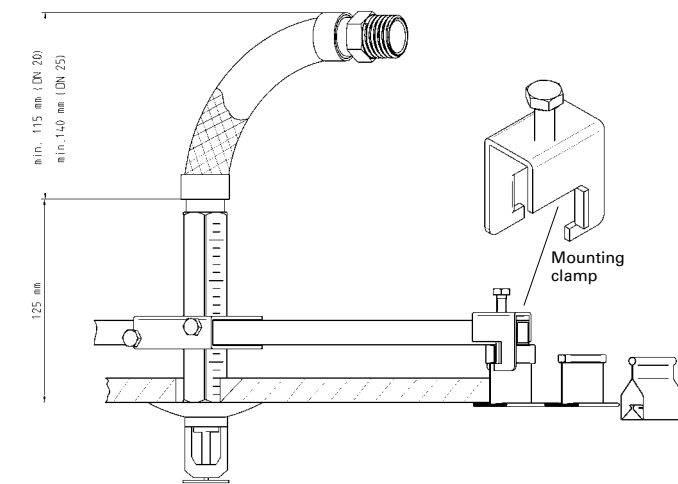

**Type 2: for hanging standard sprinklers and concealed sprinklers**

For concealed sprinklers we recommend the variable sprinkler mounting system with a larger construction height (see mounting diagram below). The mounting clamps ("Multiclips") used here for mounting to the ceiling substructure are designed in such a way that the square pipe is mounted approximately 25 mm above the supporting beam of the ceiling substructure and therefore provides sufficient installation height for the mounting of concealed or recessed sprinklers. This mounting system is also suitable and approved for hanging standard sprinklers.

**Areas of application Type 2:**

- for hanging standard sprinklers
- suitable for concealed or recessed sprinklers
- suitable for all commercially available T-bar lay-in-ceilings (with mineral fibre board or metal cassettes)
- Mounting on main or auxiliary T-bars
- Clamping profile ceiling systems
- Plasterboard ceiling systems (U-shaped profile rails 60/27)
- Mounting clamps suitable for round and angled contours (profile width > 5mm).

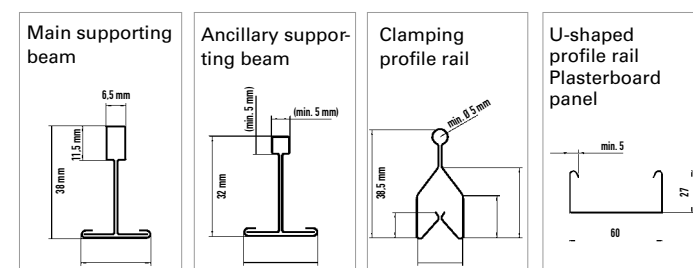
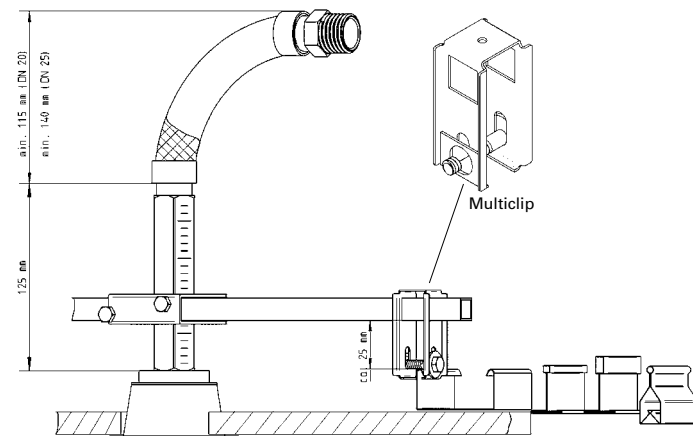

**3. MOUNTING**

**3.1. Sealing the sprinkler**

The sprinkler must be sealed to the hex-socket (Rp 1/2"=SW27, Rp 3/4" = SW30) on the sprinkler hose. The maximum permissible torque is 40 Nm. After sealing the sprinkler must be fitted with a protective cap to protect against damages. If two-part rosettes are used, the sprinkler clamp along with the lock washer of the rosette must also be mounted.

**3.2. Installing the hose**

Hose installation is carried out via threaded connection to the water supply pipe. The sprinkler hose outlets should be placed on the side of the supply pipe so that the hose outlet is parallel to the concrete slab.

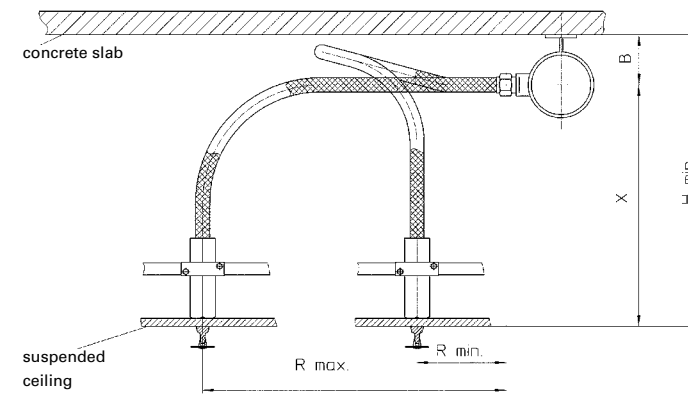

Please select distance dimensions x from the respective table (see back of page).

A distance B of at least 100 mm between the concrete slab and axis of the side sprinkler hose outlet is recommended. Where installation space is tight, the hose can also be installed in a spiral form. However, please ensure that the bending radii do not fall below the minimum permissible value.

**3.3. Preparation and installation of ceiling components**

The ceiling component designated for the mounting of the sprinkler must be fitted with a drill hole/boring on site; the hole diameter will depend on the sprinkler and rosette type. The ceiling component fitted with the drill hole/boring must be mounted according to the mounting guidelines of the ceiling system manufacturer.

**3.4. Mounting the square pipe to the ceiling system**

**Type 1:**

The bracket is mounted on two parallel profile rails of the ceiling substructure. For this purpose, the square pipe is initially placed on the ceiling rails at an angle of approx. 70°. The mounting clamps are then positioned loosely onto the square pipe, so that the ceiling rail runs between the two lugs on the underside of the clamps.

The square pipe is now aligned at a right angle to the profile rails and placed in its final mounting position. The mounting clamps are firmly screwed to the ceiling rails (recommended torque of 3 Nm), so that the square pipe and ceiling rails are positively connected to each other. During the final mounting stage please ensure that the angle between the square pipe and ceiling rails is as close to 90° as possible (maximum permissible deviation plus/minus 3°).



**Type 2:**

The bracket is mounted to two parallel profile rails of the ceiling substructure. First loosely clip on the mounting clamps ("Multiclips") to the two ends of the square pipe. The bracket system is then positioned on the ceiling substructure in such a way that the Multiclips initially loosely enclose the profile of

the ceiling rails. The square pipe is now aligned at a right angle to the profile rails and placed in its final mounting position. The Multiclips must be firmly screwed to the ceiling rails using self-tapping screws SW10 (recommended torque of 3 Nm).



**3.5. Mounting the sprinkler hose to the square pipe**

The sprinkler clamp is slid onto the square pipe and placed in its final mounting position. The installation location may be varied across the length of the square pipe. The socket of the sprinkler hose is now guided (where applicable, together with the sprinkler) through the sprinkler clamp, horizontally and vertically aligned and firmly screwed to the square pipe using self-tapping screws SW10. The mounting guidelines of the sprinkler manufacturer must be adhered to.

The permissible installation positions depend on the horizontal and vertical distance to the hose outlet at the supply pipe (see table on back of page). Bending of the hose immediately after the connection fittings is not permissible. If possible, the hose should be installed torsion-free.